



DEPARTMENT OF REGULATORY AND ECONOMIC RESOURCES (RER)
BOARD AND CODE ADMINISTRATION DIVISION

MIAMI-DADE COUNTY
PRODUCT CONTROL SECTION
11805 SW 26 Street, Room 208
Miami, Florida 33175-2474
T (786) 315-2590 F (786) 315-2599

www.miamidade.gov/economy

NOTICE OF ACCEPTANCE (NOA)

Fenetex Hurricane Screens
278 Talleyrand Avenue
Jacksonville, FL 32202

SCOPE:

This NOA is being issued under the applicable rules and regulations governing the use of construction materials. The documentation submitted has been reviewed and accepted by Miami-Dade County RER- Product Control Section to be used in Miami Dade County and other areas where allowed by the Authority Having Jurisdiction (AHJ).

This NOA shall not be valid after the expiration date stated below. The Miami-Dade County Product Control Section (In Miami Dade County) and/or the AHJ (in areas other than Miami Dade County) reserve the right to have this product or material tested for quality assurance purposes. If this product or material fails to perform in the accepted manner, the manufacturer will incur the expense of such testing and the AHJ may immediately revoke, modify, or suspend the use of such product or material within their jurisdiction. RER reserves the right to revoke this acceptance, if it is determined by Miami-Dade County Product Control Section that this product or material fails to meet the requirements of the applicable building code.

This product is approved as described herein, and has been designed to comply with the High Velocity Hurricane Zone of the Florida Building Code.

DESCRIPTION: "Fenetex Hurricane Screens" Wind Abatement System

APPROVAL DOCUMENT: Drawing No. 0906131, titled "Fenetex Hurricane Screens", prepared by Jorge A. Pomerantz, P.E., dated Sept. 20, 2013, Revision #3 dated June 13, 2016, sheets 1 through 9 of 9, signed and sealed by Jorge A. Pomerantz, P.E., on July 20, 2016, bearing the Miami-Dade County Product Control Revision stamp with the Notice of Acceptance number & the expiration date by the Miami-Dade County Product Control Section.

MISSILE IMPACT RATING: Large and Small Missile Impact Resistant

LABELING: Each unit shall bear a permanent label with the manufacturer's name or logo, city, state, the following statement: "Miami-Dade County Product Control Approved", and NOA number, per TAS-201, TAS-202, and TAS-203, unless otherwise noted herein.

RENEWAL of this NOA shall be considered after a renewal application has been filed and there has been no change in the applicable building code negatively affecting the performance of this product.

TERMINATION of this NOA will occur after the expiration date or if there has been a revision or change in the materials, use, and/or manufacture of the product or process. Misuse of this NOA as an endorsement of any product, for sales, advertising or any other purposes shall automatically terminate this NOA. Failure to comply with any section of this NOA shall be cause for termination and removal of NOA.

ADVERTISEMENT: The NOA number preceded by the words Miami-Dade County, Florida, and followed by the expiration date may be displayed in advertising literature. If any portion of the NOA is displayed, then it shall be done in its entirety.

INSPECTION: A copy of this entire NOA shall be provided to the user by the manufacturer or its distributors and shall be available for inspection at the job site at the request of the Building Official.

This NOA revises NOA # 13-1007.08 and consists of this page 1, evidence submitted pages E1 and E-2 as well as approval document mentioned above.

The submitted documentation was reviewed by **Helmy A. Makar, P.E., M.S.**



Helmy A. Makar
07/06/2017

NOA No. 16-0921.10
Expiration Date: 12/04/2019
Approval Date: 07/06/2017

Fenetex Hurricane Screens

NOTICE OF ACCEPTANCE: EVIDENCE SUBMITTED

1. EVIDENCE SUBMITTED UNDER PREVIOUS APPROVAL # 13-1007.08

A. DRAWINGS

1. *Drawing No. 0906131, titled "Fenetex Hurricane Screens", prepared by Jorge A. Pomerantz, P.E., dated Sept. 20, 2013, Revision #2 dated October 22, 2014, sheets 1 through 9 of 9, signed and sealed by Jorge A. Pomerantz, P.E., on November 03, 2014.*

B. TESTS

1. *Test Report per Testing Standards TAS 201, TAS 202 and TAS 203.*

C. CALCULATIONS

1. *Structural calculations and analysis of test results prepared by by ING Consultants, Inc., dated February 17, 2014, signed and sealed by Jorge A. Pomerantz, P.E.*

D. MATERIAL CERTIFICATIONS

1. *None*

E. STATEMENTS

1. *FBC, 2010 Edition Code Compliance and no financial interest letter by ING Consultants, Inc., dated February 17, 2014, signed and sealed by Jorge A. Pomerantz, P.E.*

F. QUALITY ASSURANCE

1. *Miami-Dade County Building Code Compliance Office.*

2. NEW EVIDENCE SUBMITTED

A. DRAWINGS

1. *Drawing No. 0906131, titled "Fenetex Hurricane Screens", prepared by Jorge A. Pomerantz, P.E., dated Sept. 20, 2013, Revision #3 dated June 13, 2016, sheets 1 through 9 of 9, signed and sealed by Jorge A. Pomerantz, P.E., on July 20, 2016.*

B. TESTS

1. *None.*

C. CALCULATIONS

1. *None.*

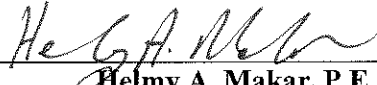

Helmy A. Makar, P.E., M.S.
Product Control Section Supervisor
NOA No. 16-0921.10
Expiration Date: 12/04/2019
Approval Date: 07/06/2017

Fenetex Hurricane Screens

NOTICE OF ACCEPTANCE: EVIDENCE SUBMITTED

D. QUALITY ASSURANCE

1. *By Miami-Dade County Department of Regulatory and Economic Resources (RER).*

E. MATERIAL CERTIFICATIONS

1. *None.*

F. STATEMENTS

1. *FBC, 2014 Edition Code Compliance letter by ING Consultants, Inc., dated September 08, 2016, signed and sealed by Jorge A. Pomerantz, P.E.*



Helmy A. Makar, P.E., M.S.
Product Control Section Supervisor
NOA No. 16-0921.10
Expiration Date: 12/04/2019
Approval Date: 07/06/2017

FENETEX HURRICANE SCREENS
IMPACT RESISTANT WIND ABATEMENT SYSTEM



CONNECTION TYPE A: CLIP & ROD
+/-76 PSF MAX SPAN 168"



CONNECTION TYPE D: SCREW CLIP
+/-76 PSF MAX SPAN 120"



CONNECTION TYPE E: WEBBING ASSEMBLY
+/-76 PSF MAX SPAN 192"



END RETENTION SCREENS
+/-76 PSF MAX SPAN 192"

TABLE OF CONTENTS:

PRODUCT DESCRIPTION

- PAGE 1 GENERAL NOTES
- PAGE 2 DIRECT MOUNT SCREEN CONNECTIONS
- PAGE 3 WEBBING ASSEMBLY CONNECTIONS
- PAGE 4 SCREEN TO SCREEN CONNECTIONS
- PAGE 5 TRACK TYPES & MATERIALS SPECIFICATION
- PAGE 6 END RETENTION SCREENS

ANCHOR SCHEDULES

- PAGE 7 CONNECTION TYPE A OUT/INSIDE MOUNTS
- PAGE 8 CONNECTION TYPE D OUT/INSIDE MOUNTS
- PAGE 9 CONNECTION TYPE E & END RETENTION SCREENS OUT/INSIDE MOUNTS

GENERAL NOTES:

1. THE SYSTEM DESCRIBED HEREIN HAS BEEN DESIGNED AND TESTED AS A LARGE AND SMALL MISSILE WIND ABATEMENT AND IMPACT PROTECTIVE SYSTEM IN ACCORDANCE WITH THE FLORIDA BUILDING CODE FOR USE INSIDE THE HIGH VELOCITY HURRICANE ZONE (HVHZ) PER TAS 201-94, TAS 202-94 AND TAS 203-94.
2. THE SYSTEM DESCRIBED HEREIN IS DESIGNED FOR USE AS A PROTECTED OPENING IMPACT SCREEN DURING PERIODS OF HIGH WINDS. THE SCREEN IS TEMPORARY AND REMOVABLE AND SHALL NOT BE PERMANENTLY DEPLOYED OR INSTALLED. WHEN SCREEN IS NOT BEING USED FOR ITS INTENDED PURPOSE THE SCREEN SHALL BE REMOVED AND STORED.
3. THIS SYSTEM DESCRIBED HEREIN HAS A WEAVE DENSITY AND CONSTRUCTION SUCH THAT IT PREVENTS SUBSTANTIAL WATER INTRUSION INTO A BUILDING DURING HURRICANE CONDITIONS.
4. THE SYSTEM DESCRIBED HEREIN IS GENERIC AND DOES NOT PROVIDE INFORMATION FOR A SPECIFIC SITE. A LICENSED ENGINEER OR REGISTERED ARCHITECT SHALL PREPARE SITE SPECIFIC DOCUMENTS FOR USE WITH THIS DOCUMENT AS REQUIRED FOR INSTALLATIONS OUTSIDE THE SCOPE OF THE SYSTEM HEREIN.
5. PERMIT HOLDER SHALL VERIFY THE ADEQUACY OF THE EXISTING STRUCTURE TO WITHSTAND SUPERIMPOSED LOADS.
6. THE SCREEN DESCRIBED HEREIN SHALL BE PERMANENTLY LABELED AND CONTAIN "FENETEX, INC." CURRENT ADDRESS, MIAMI-DADE COUNTY PRODUCT CONTROL APPROVED.

INSTALLATION NOTES:

1. THE UNBREACHED ENVELOPE IS PROVIDED WHEN PROTECTIVE SCREENS ARE INSTALLED IN A MANNER TO COMPLETELY COVER THE ENTIRE OPENING IN ALL DIRECTIONS. ON ANY SIDE OF AN OPENING, THE MAXIMUM SIDE CLEARANCE BETWEEN THE SCREEN AND A WALL OR INSET SURFACE SHALL BE 1/4". ANY DISTANCE IN EXCESS OF 1/4" SHALL REQUIRE END CLOSURE OR SCREEN OVERLAP OF A MINIMUM OF 1.5 TIMES THE SIDE CLEARANCE BETWEEN THE SCREEN AND WALL.
2. MULTIPLE UNITS MAY BE INSTALLED TO UNLIMITED NON-SPAN WIDTHS.
3. SCREENS MAY BE MOUNTED VERTICALLY, HORIZONTALLY OR AT ANY ANGLE AND AT ANY HEIGHT ON A BUILDING SO LONG AS DESIGN PRESSURE IS NOT EXCEEDED.
4. MINIMUM GLAZING SEPARATION BETWEEN GLAZING AND SCREEN IS MEASURED AT MID-SPAN OF SCREEN FOR THE INDICATED SPAN. MINIMUM SEPARATION IS MAXIMUM SCREEN DEFLECTION AT INDICATED SPAN AND DESIGN PRESSURE PLUS 1". BUILD-OUTS, BLOCKING, STORM BARS AND TENTING OF SCREENS MAY BE USED TO INCREASE SEPARATION IF REQUIRED TO ACHIEVE 1" OF SEPARATION BETWEEN SCREEN AND GLAZING AT MAXIMUM SCREEN DEFLECTION.
5. MULTIPLE CONNECTION TYPES AND TRACK TYPES MAY BE USED FOR ANY OPENING. THE ANCHOR SPACING MUST SOLVE FOR THE WEAKEST CONDITION PRESENT IN THE COMBINATION.
6. SCREEN SYSTEMS BEAR LOADS ON TWO OPPOSING SIDES. THIS IS THE SPAN DIRECTION. THE NON-SPAN DIRECTION MAY HAVE ADDITIONAL OPTIONAL ATTACHMENT POINTS.
7. SPAN IS MEASURED ANCHOR TO ANCHOR.

PRODUCT REVISED
as complying with the Florida
Building Code
Acceptance No 16-0921.10
Expiration Date 12/04/2019
By *[Signature]*
Miami Dade Product Control

ANCHOR NOTES:

1. MINIMUM EDGE DISTANCE AND EMBEDMENT EXCLUDES ALL WALL FINISHES INCLUDING BUT NOT LIMITED TO STUCCO, FOAM, BRICK VENEER, AND SIDING.
2. THE ANCHOR SCHEDULE REFERENCES THE INDICATED MANUFACTURER'S INSTALLATION INSTRUCTIONS AND TEST RESULTS. INSTALL ALL ANCHORS PER MANUFACTURER'S DIRECTIONS.
3. ANCHOR CONNECTIONS SHALL BE MADE WITH CORRESPONDING MACHINE SCREWS HAVING A MINIMUM TENSILE STRESS OF 45,000 PSI. CONNECTIONS MAY USE WASHER WING NUTS OR BOLTS WITH WASHERS OF MIN. HEAD DIA. TWICE THE DIA. OF OPENING.

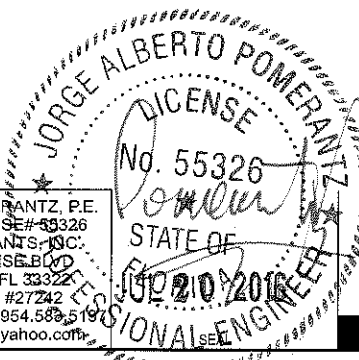

JORGE A. POMERANTZ, P.E.
FLORIDA LICENSE # 55326
ING CONSULTANTS, INC.
8865 W SUNRISE BLVD
PLANTATION FL 33322
CERT. AUTH. #27242
T: 954.394.8521 F: 954.582.5197
ingconsultants@yahoo.com



FENETEX
HURRICANE SCREENS

Installation Instructions

278 Talleyrand Ave
Jacksonville, FL 32202
Tel: 904.437.5168
www.fenetex.com

DRAWINGS BY FENETEX, INC.
COPYRIGHT 2013 FENETEX, INC.
INIT ISSUE 09.20.2013
REV 3 06.13.2016

DRAWING NO:
0906131
NOT TO SCALE

1 of
9

DIRECT MOUNT SCREEN CONNECTIONS

TYPE A CONNECTION CLIP & ROD

DOUBLE FOLD EDGE 3" HEM WITH FABRIC #1 WITH THREE ROWS OF STITCHING AT 5 STITCHES PER INCH WHERE INDICATED BY DOTTED LINE. FRP ROD INSERTED IN HEM, FIRST CLIP NOT MORE THAN 7" FROM PANEL EDGE. MAX SPAN, DESIGN PRESSURE, ANCHOR TYPE AND SPACING PER ANCHOR SCHEDULE.

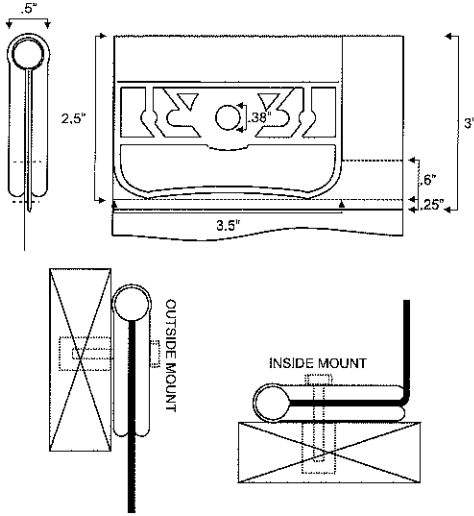

TYPE D CONNECTION SCREW CLIP

DOUBLE FOLD EDGE 3" HEM WITH FABRIC #1 WITH STITCHING AT 5 STITCHES PER INCH WHERE INDICATED BY DOTTED LINE. CLIP IS SECURED TO SCREEN WITH (5) #8X1/2" S/S SCREWS. FIRST CLIP NOT MORE THAN 3" FROM PANEL EDGE. MAX SPAN, DESIGN PRESSURE, ANCHOR TYPE AND SPACING PER ANCHOR SCHEDULE.

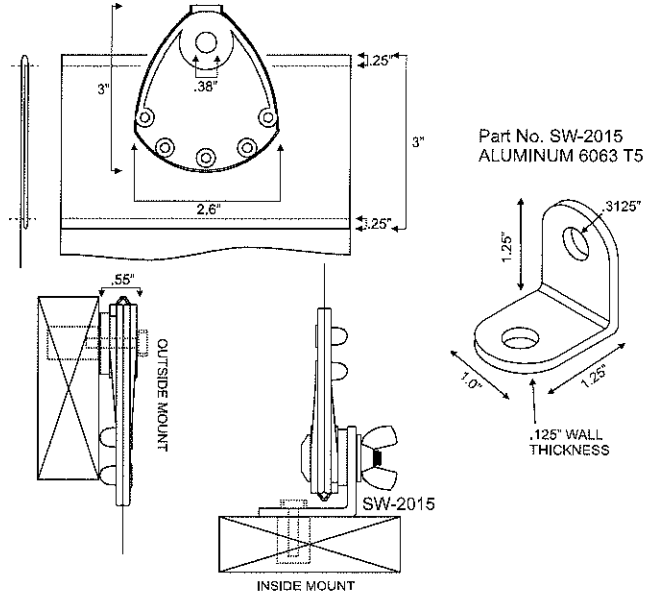

TYPE E CONNECTION WEBBING ASSEMBLY

DOUBLE FOLD EDGE 3" HEM WITH FABRIC #1 WITH STITCHING AT 5 STITCHES PER INCH WHERE INDICATED BY DOTTED LINE. STRAP BASE - 7"X3" SYNTHETIC WEBBING. BASE AND 2" STRAP WEBBING ASSEMBLY ATTACHED TO SCREEN WITH THREE ROWS OF DOUBLE STITCHING AT 5 STITCHES PER INCH WHERE INDICATED BY DOTTED LINE. FIRST ASSEMBLY NOT MORE THAN 7" FROM PANEL EDGE. MAX SPAN, DESIGN PRESSURE, ANCHOR TYPE AND SPACING PER ANCHOR SCHEDULE.

NOTE: TYPE E CONNECTION OPTIONS ON PAGE 3

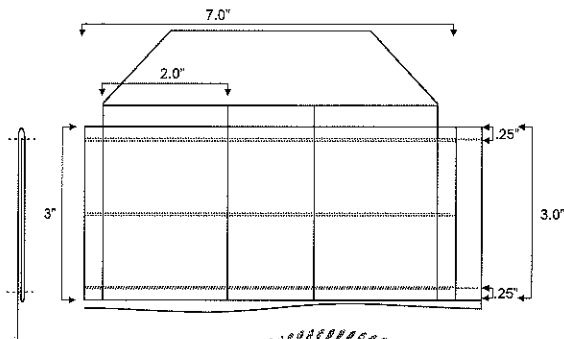

EDGE REINFORCEMENT WOVEN SCREENS

EDGE REINFORCEMENT:
2" or 3" HEM WITH TWO ROWS OF STITCHING AT 5 STITCHES PER INCH FOR NON ANCHORED EDGES.

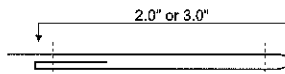

PRODUCT REVISED
as complying with the Florida
Building Code
Acceptance No 16-0921-10
Expiration Date 12/04/2019
By *[Signature]*
Miami Dept Product Control

ALLOWABLE MOUNTING CONDITIONS

DOTTED LINE REPRESENTS
MAX DEFECTION

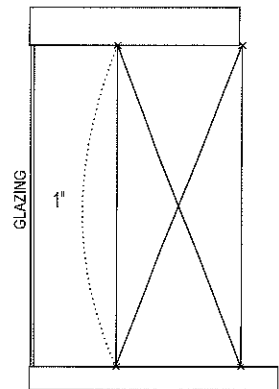

DEFLECTION AND SEPARATION

| CONNECTION | SPAN | MAXIMUM DEFLECTION | MINIMUM SEPARATION |
|------------|------|--------------------|--------------------|
| TYPE A | 168" | 28" | 29" |
| TYPE D | 120" | 30" | 31" |
| TYPE E | 192" | 31" | 32" |

JORGE A. POMERANTZ, P.E.
FLORIDA LICENSE# 55326
ING CONSULTANTS, INC.
8865 W SUNRISE BLVD
PLANTATION FL 33322
CERT. AUTH. #27242
T: 954.394.8521 F: 954.583.5197
ingconsultants@yahoo.com

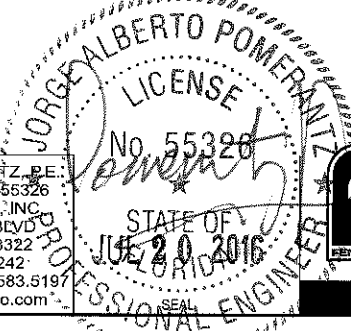

FENETEX
HURRICANE SCREENS

Installation Instructions

278 Talleyrand Ave
Jacksonville, FL 32202
Tel: 904.437.5168
www.fenetex.com

DRAWINGS BY FENETEX, INC.
COPYRIGHT 2013 FENETEX, INC.
INIT ISSUE 09.20.2013
REV 3 06.13.2016

DRAWING NO:
0906131
NOT TO SCALE

2 of
9

WEBBING ASSEMBLY CONNECTION TYPES

TYPE E OPTIONAL CONFIGURATIONS

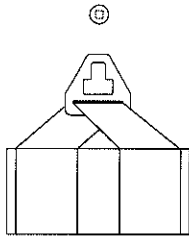

KEYHOLE CLIP

RAPID DEPLOYMENT AND REMOVAL OF HURRICANE BARRIER WITHOUT ADDITIONAL HARDWARE.

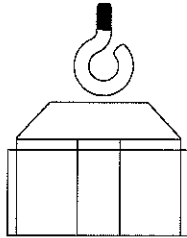

LOOP

LOOP AND EYE-BOLT CONFIGURATION FOR USE WITH CONCEALED ANCHORS.

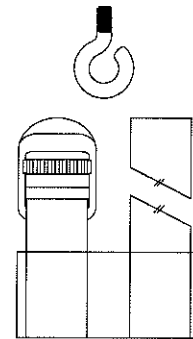

STRAP & BUCKLE

USED ON OPPOSING SIDE/S OR WITH OTHER ASSEMBLY TYPES TO TENSION HURRICANE BARRIER.

TYPE E CONNECTION OPTIONS

KEYHOLE 304 s/s
PART No. SW-301

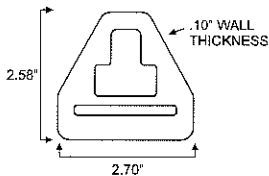

3/8" or 1/2" CARRIAGE BOLT
304 s/s

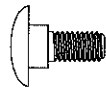

3/8" OR 1/2" CLOSED
EYE-BOLT 304 s/s

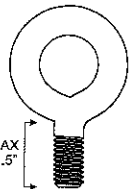

1/2" OPEN EYE-BOLT
304 s/s

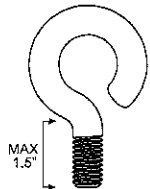

BUCKLE
PART No. SW-302

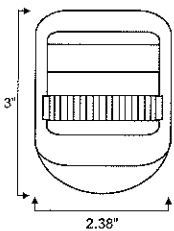

TYPE E NOTES:

1. LOOP AND STRAP & BUCKLE MAY BE INSIDE OR OUTSIDE MOUNT.
2. KEYHOLE CLIP IS OUTSIDE MOUNT ONLY.
3. ONLY 3/8" AND 1/2" CLOSED AND 1/2" OPEN EYEBOLTS CAN BE USED WITH ANY ALLOWABLE SPAN AND ANCHOR COMBINATION.
4. CARRIAGE AND/OR EYE-BOLTS SHALL BE MOUNTED AS CLOSE TO SUBSTRATE SURFACE AS POSSIBLE. WHERE ANCHOR EMBEDMENT REQUIRES LONGER SHANK THAN SHOWN, SHANK SHALL BE STRUCTURALLY SUPPORTED TO SUBSTRATE SURFACE.

INSIDE MOUNT

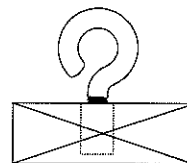

OUTSIDE MOUNT

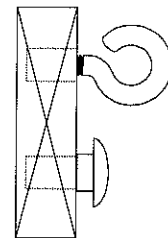

PRODUCT REVISED

as complying with the Florida
Building Code
Acceptance No 16-0921.10
Expiration Date 12/04/2019
By *Heggy Allen*
Miami Dade Product Control

JORGE A. POMERANTZ, P.E.
FLORIDA LICENSE# 55326
ING CONSULTANTS, INC.
8865 W SUNRISE BLVD
PLANTATION FL 33322
CERT. AUTH. #27242
T: 954.394.8521 F: 954.583.5197
ingconsultants@yahoo.com

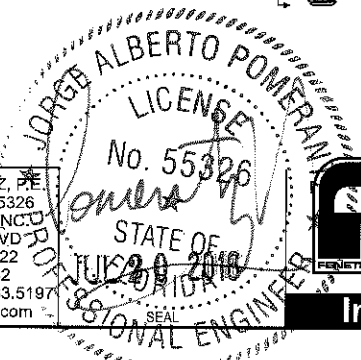

FENETEX
HURRICANE SCREENS

278 Talleyrand Ave
Jacksonville, FL 32202
Tel: 904.437.5168
www.fenetex.com

DRAWINGS BY FENETEX, INC.
COPYRIGHT 2013 FENETEX, INC.
INIT ISSUE 02.20.2013
REV 3 06.13.2016

DRAWING NO:
0906131
NOT TO SCALE

3 of
9

SCREEN TO SCREEN CONNECTIONS

HIDDEN FLAP CONNECTION:

4" FLAP ATTACHED TO FIRST SCREEN EDGE WITH ONE ROW OF STITCHING AT 5 STITCHES PER INCH. FLAP CONNECTS TO COMPLIMENTARY #2 GROMMET ON SECOND SCREEN EDGE.

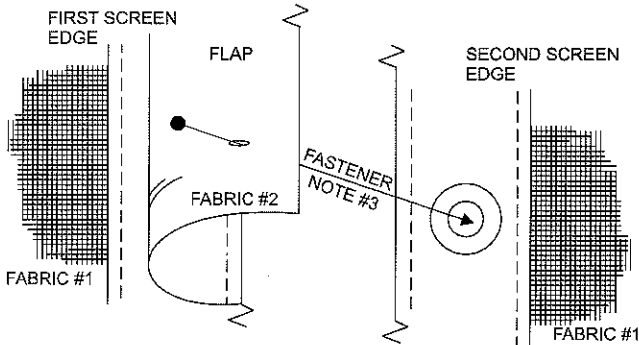

FLAP CONNECTION:

4" FLAP ATTACHED TO FIRST SCREEN EDGE WITH ONE ROW OF STITCHING AT 5 STITCHES PER INCH. FLAP CONNECTS TO COMPLIMENTARY #2 GROMMET ON SECOND SCREEN EDGE.

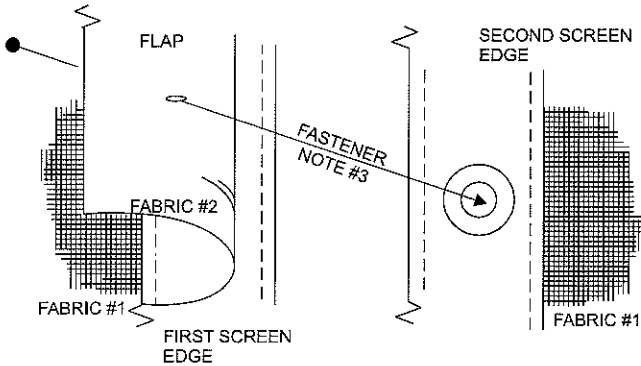

GROMMET CONNECTION:

COMPLIMENTARY #2 GROMMETS ON FIRST AND SECOND SCREEN EDGES.

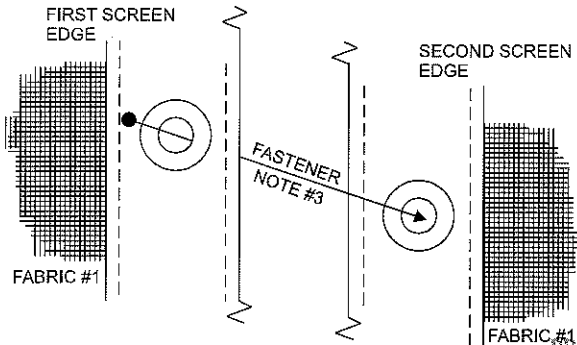

CONNECTING TWO SCREENS:

1. MULTIPLE SCREENS MAY BE CONNECTED TO ANY LENGTH.
2. CONNECTION SPACING IS 12" O.C. UNLESS OTHERWISE INDICATED
3. FASTENERS ARE 1/4"-20 SIDEWALK BOLT W/ WASHERED WING NUT.

BUCKLE CONNECTION:

BUCKLE ASSEMBLY SEWN TO FIRST AND SECOND SCREEN EDGES WITH TWO ROWS OF STITCHING AT 5 STITCHES PER INCH. SCREENS OVERLAP ONE ANCHOR. BUCKLE SPACING IS 24"

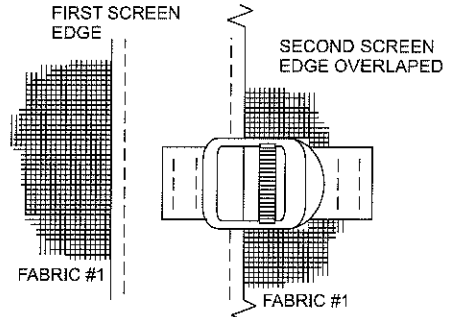

HINGE STRIP CONNECTION:

PANELS ATTACHED TO FIRST AND SECOND SCREEN EDGES WITH 4" INTERMEDIARY FABRIC STRIP WITH TWO ROWS OF STITCHING AT 5 STITCHES PER INCH.

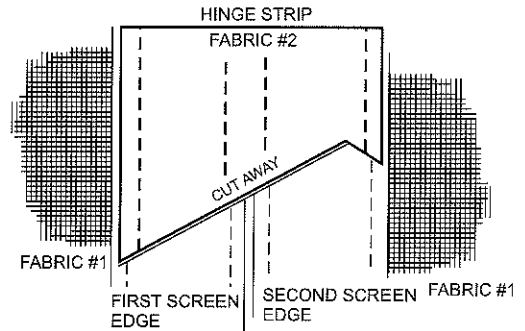

SEWN SEAM:

2" SEAM WITH TWO ROWS OF STITCHING AT 5 STITCHES PER INCH. USED WHEN SEWING TWO PANEL SECTIONS TOGETHER, ANY FABRIC.

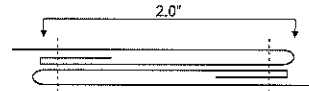

WELDED SEAM:

1" THERMAL OR CHEMICAL WELD WHEN JOINING TWO SECTIONS OF FABRICS #2.

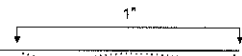

PRODUCT REVISED

as complying with the Florida Building Code
Acceptance No 16-0921-10
Expiration Date 12/04/2019

By *Hubert A. Albu*
Miami Dept. Product Control

JORGE A. POMERANTZ, P.E.
FLORIDA LICENSE# 55326
ING CONSULTANTS, INC.
8865 W SUNRISE BLVD
PLANTATION FL 33322
CERT. AUTH. #27242
T: 954.394.8521 F: 954.583.5199
ingconsultants@yahoo.com



FENETEX
HURRICANE SCREENS

278 Talleyrand Ave
Jacksonville, FL 32202
Tel: 904.437.5168
www.fenetex.com

DRAWINGS BY FENETEX, INC.
COPYRIGHT 2013 FENETEX, INC.
INIT ISSUE 09.20.2013
REV 3 06.13.2016

DRAWING NO:
0906131
NOT TO SCALE

4 of 9

TRACK TYPES

MATERIALS SPECIFICATION

STRUCTURAL ANGLE TRACK FOR USE WITH CONNECTION TYPE A

1/8" ALUMINUM ANGLE FOR 12" ANCHOR SPACING SEE NOTE #4

3/16" ALUMINUM ANGLE MAX 24" ANCHOR SPACING SEE NOTE #5

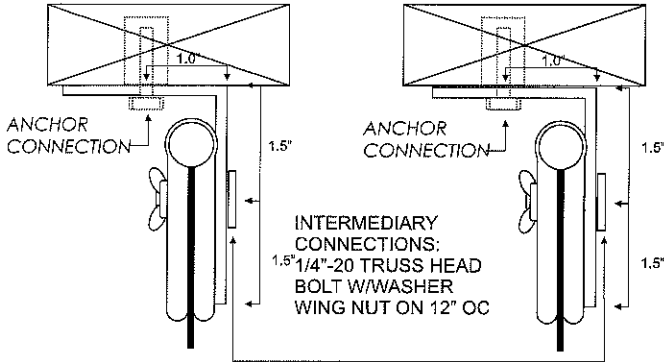

TRACK NOTES:

1. TRACK TO HOST STRUCTURE ANCHOR CONNECTIONS PER ANCHOR SCHEDULE.
2. TRACK CAN BE FLOOR OR CEILING MOUNTED.
3. INTERMEDIARY CONNECTIONS IN ANGLE TRACK MAY USE 1/4-20 TRUSS HEAD MACHINE SCREWS WITH WASHER WING NUT OR NUT WITH WASHER FOR A MIN. HEAD DIA. TWICE THE DIA. OF OPENING.
4. MAX 2"x3" ALUMINUM ANGLE WITH A MIN. 1/8" THICK AND OF A CONTINUOUS OR SEGMENTED SECTION WITH A MIN. LENGTH OF 3.5" MAY BE USED WITH MAX 12" O.C. ANCHORS INTO SUBSTRATE PER ANCHOR SCHEDULE. INTERMEDIARY PANEL TO ANGLE CONNECTIONS ARE SPACED ON 12" CENTERS.
5. CONTINUOUS SECTIONS OF 2"x3" ALUMINUM ANGLE WITH A MIN 3/16" THICK MAY BE USED WITH MAX 24" O.C. ANCHORS INTO SUBSTRATE TO MAX. SPAN PER ANCHOR SCHEDULE. INTERMEDIARY PANEL TO ANGLE CONNECTIONS ARE SPACED ON 12" CENTERS.

**MATERIALS SPECIFICATION
MINIMUM AVERAGE VALUES**

FABRIC 1: POLYMESH
 FIBER CONTENT SYNTHETIC POLYMER - PROPRIETARY
 CONSTRUCTION BALLISTIC WEAVE
 WEIGHT (ASTM D3776, D5261) 9.0 OZ/ YARD
 GRAB TENSILE (ASTM D4632) 500 LBS WARP X 475 LBS WEFT
 PUNCTURE (ASTM D4833) 185 LBS
 MULLEN BURST (ASTM D3786) 850 PSI
 POROSITY 5% (NON-POROUS)

FABRIC 2: PVC MESH
 FIBER CONTENT SYNTHETIC POLYMER - PROPRIETARY
 CONSTRUCTION PVC COATED SCRIM
 WEIGHT (ASTM D751) 400Z/SQ YARD
 GRAB TENSILE (ASTM D5034) 950 X 900 LBS 2"
 THICKNESS .04"
 POROSITY 0% (NON-POROUS)

CLAMP OF CONNECTION TYPE A & TYPE D:
 MATERIAL SYNTHETIC POLYMER - PROPRIETARY
 TENSILE YIELD (ASTM D638) 7,000 PSI
 FLEXURAL MODULUS (ASTM D790) 250,000 PSI

STRAP OF CONNECTION TYPE E:
 BASE (NON-STRUCTURAL) 3" SYNTHETIC WEBBING
 2" STRUCTURAL WEBBING SYNTHETIC MIN. TENSILE 2,500LBS

OTHER COMPONENTS:
 SW-2015 AL 6063 T5
 SW-301 304 S/S MIN. CAP. 2500LBS
 SW-302 SYNTHETIC POLYMER - PROPRIETARY
 MIN. CAP 900LBS
 2"x3"x1/8" ANGLE AL 6063 T5
 2"x3"x3/16" ANGLE AL 6063 T5
 2"x3"x1/4" ANGLE AL 6063 T5
 1"x3"x1/4" TUBE AL 6063 T5
 2"x3"x1/4" TUBE AL 6063 T5

PRODUCT REVISED
 as complying with the Florida
 Building Code
 Acceptance No 16-0921.10
 Expiration Date 12/04/2019
 By *Heber A. Miller*
 Miami Dept Product Control

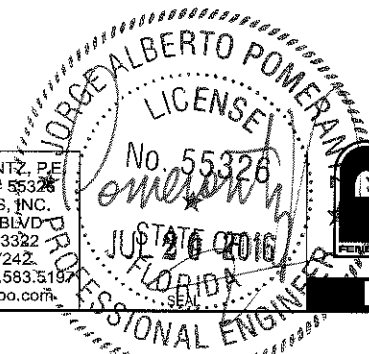

JORGE A. POMERANTZ, P.E.
 FLORIDA LICENSE# 55326
 ING CONSULTANTS, INC.
 8865 W SUNRISE BLVD
 PLANTATION FL 33322
 CERT. AUTH. #27242
 T: 954.394.8521 F: 954.583.5197
 ingconsultants@yahoo.com



FENETEX
 HURRICANE SCREENS

Installation Instructions

278 Talleyrand Ave
 Jacksonville, FL 32202
 Tel: 904.437.5168
 www.fenetex.com

DRAWINGS BY FENETEX, INC.
 COPYRIGHT 2013 FENETEX, INC.
 INIT ISSUE 09.20.2013
 REV 3 06.13.2016

DRAWING NO: 0906131
 NOT TO SCALE **5** of 9

END RETENTION SCREENS

END RETENTION SCREEN SYSTEM

SINGLE FOLD EDGE 2" HEM WITH FABRIC #1 WITH STITCHING AT 5 STITCHES PER INCH AS INDICATED. HEM CORD SEWN TO HEM WITH THREE ROWS OF STITCHING. MIN. HEM CORD DIA. .236" CAN BE SOLID PVC OR BRAIDED CORD. HEM CORD SLIDES INTO TRACK GROOVE.

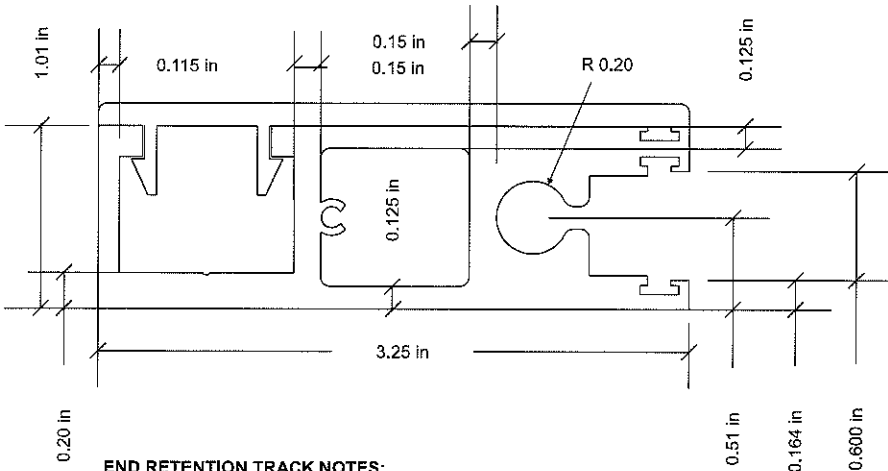
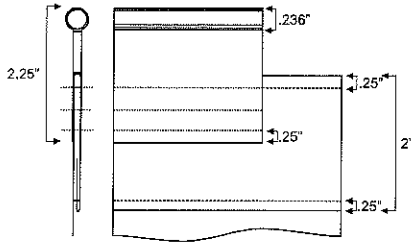

END RETENTION TRACK NOTES:

- COMPONENTS A, B AND E ARE OPTIONAL AND INDEPENDENT OF THE END RETENTION SCREEN SYSTEM HEREIN. SYSTEM USE AND CONFIGURATION OF OPTIONAL COMPONENTS SHALL BE INSTALLED PER APPLICABLE BUILDING CODES WHERE REQUIRED.
- END RETENTION TRACKS ARE SECURED TO SUBSTRATE PER ANCHOR SCHEDULE. SPAN IS THE DISTANCE BETWEEN OPPOSING ANCHORS.
- 2"x3" ANGLE AND TUBE ARE COMPRISED OF ALUMINUM OF 6063 T5 WITH MIN. 1/4" WALL THICKNESS.
- TRACK CONNECTIONS TO ANGLE AND TUBE ARE MADE WITH 1/4-14x1" ITW/BUILDDEX HWH TEKS SELECT. FASTENER SPACING IS 4" O.C. TO 192" SPAN.

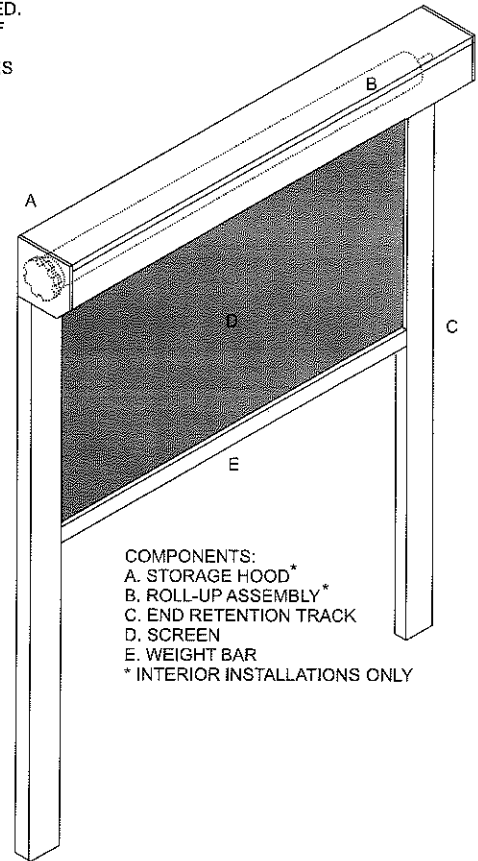

- COMPONENTS:
 A. STORAGE HOOD*
 B. ROLL-UP ASSEMBLY*
 C. END RETENTION TRACK
 D. SCREEN
 E. WEIGHT BAR
 * INTERIOR INSTALLATIONS ONLY

DEFLECTION AND SEPARATION

| CONNECTION | SPAN | MAXIMUM DEFLECTION | MINIMUM SEPARATION |
|---------------|------|--------------------|--------------------|
| END RETENTION | 192" | 31" | 32" |

FASTENER SPACING FOR TRACK TO ANGLE AND TRACK TO TUBE CONNECTIONS IS 4" O.C. FOR ALL SPANS UP TO 192". SEE NOTE #4.

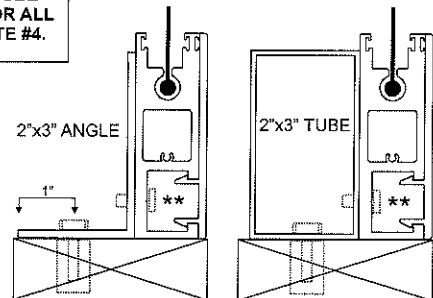
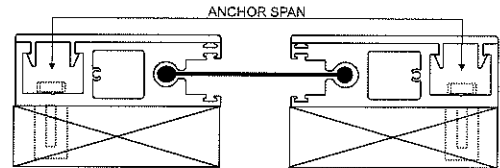

**SEE NOTES #3 AND #4

PRODUCT REVISED
 as complying with the Florida
 Building Code
 Acceptance No 16-0921-10
 Expiration Date 12/04/2019
 By *[Signature]*
 Miami Design Product Control

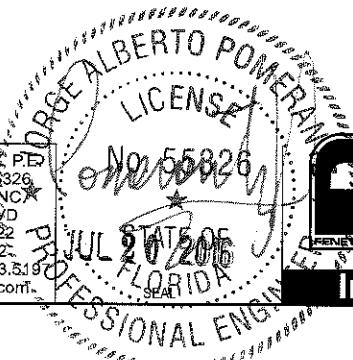

JORGE A. POMERANTZ, P.E.
 FLORIDA LICENSE# 55826
 ENGINEERING CONSULTANTS, INC.
 8865 W SUNRISE BLVD
 PLANTATION FL 33322
 CERT. AUTH. #27242Z
 T: 954.394.8521 F: 954.583.3197
 ingconsultants@yahoo.com



FENETEX
 HURRICANE SCREENS

Installation Instructions

278 Talleyrand Ave
 Jacksonville, FL 32202
 Tel: 904.437.5168
 www.fenetex.com

DRAWINGS BY FENETEX, INC.
 COPYRIGHT 2013 FENETEX, INC.
 INIT ISSUE 09.20.2013
 REV 3 06.13.2016

DRAWING NO: 0906131
 NOT TO SCALE **6** of 9

ANCHOR SCHEDULE CONNECTION TYPE A

BLANK CELLS OR GREATER SPANS
REQUIRE SITE SPECIFIC ENGINEERING

+/- 76PSF DESIGN PRESSURE AT 168" SPAN OUTSIDE MOUNT

MAX SUPERIMPOSED LOADS/FT
SPAN 168" AND +/- 76PSF
TENSION 532 LBS
SHEAR 862 LBS

| ANCHOR | | MIN EMBED | MIN EDGE DIST | SPANS TO: 60" | SPANS TO: 72" | SPANS TO: 84" | SPANS TO: 96" | SPANS TO: 108" | SPANS TO: 120" | SPANS TO: 132" | SPANS TO: 144" | SPANS TO: 156" | SPANS TO: 168" |
|--------------|-----------------------------------|-----------|---------------|---------------|---------------|---------------|---------------|----------------|----------------|----------------|----------------|----------------|----------------|
| WOOD SG=0.55 | 1/4"ELCO PANELMATE MALE OR FEMALE | 1-7/8" | 3/4" | 9" O.C. | 7" O.C. | 6" O.C. | | | | | | | |
| | 1/4"ELCO PANELMATE MALE OR FEMALE | 1-1/2" | 2" | 11" O.C. | 9" O.C. | 8" O.C. | 7" O.C. | 6" O.C. | | | | | |
| | 1/4" LAG BOLT | 3" | 1-3/4" | 12" O.C. | 12" O.C. | 12" O.C. | 12" O.C. | 12" O.C. | 10" O.C. | 9" O.C. | 8" O.C. | 7" O.C. | 7" O.C. |
| | 3/8" LAG BOLT | 3" | 1-3/4" | 12" O.C. | 12" O.C. | 12" O.C. | 12" O.C. | 12" O.C. | 12" O.C. | 12" O.C. | 12" O.C. | 12" O.C. | 11" O.C. |

| | | | | | | | | | | | | | |
|-------------------|----------------------------|---------|---------|----------|----------|----------|----------|----------|----------|---------|---------|---------|---------|
| CONCRETE 3000 psi | 1/4"ELCO PANELMATE MALE | 2" | 2-1/2" | 12" O.C. | 11" O.C. | 9" O.C. | 8" O.C. | 7" O.C. | 6" O.C. | 6" O.C. | | | |
| | 1/4"ELCO PANELMATE FEMALE | 1-3/4" | 2-1/2" | 10" O.C. | 9" O.C. | 7" O.C. | 7" O.C. | 6" O.C. | | | | | |
| | 1/4" ELCO PANELMATE INSERT | 1-5/8" | 4" | 12" O.C. | 11" O.C. | 10" O.C. | 8" O.C. | 7" O.C. | 7" O.C. | 6" O.C. | | | |
| | 1/4-20 POWERS CALK-IN | 7/8" | 3" | 9" O.C. | 8" O.C. | 7" O.C. | 6" O.C. | | | | | | |
| | 1/4" TAPCON | 1-3/4" | 2-1/2" | 11" O.C. | 9" O.C. | 7" O.C. | 6" O.C. | | | | | | |
| | 5/16" TAPCON | 2-1/4" | 2-3/16" | 12" O.C. | 12" O.C. | 12" O.C. | 12" O.C. | 10" O.C. | 9" O.C. | 9" O.C. | 8" O.C. | 7" O.C. | 7" O.C. |
| | 3/8-16 POWERS CALK-IN | 1-1/4" | 4" | 12" O.C. | 12" O.C. | 11" O.C. | 10" O.C. | 9" O.C. | 8" O.C. | 7" O.C. | 6" O.C. | 6" O.C. | |
| | 3/8 POWERS DROP-IN | 1-9/16" | 2-5/8" | 12" O.C. | 12" O.C. | 12" O.C. | 12" O.C. | 11" O.C. | 10" O.C. | 9" O.C. | 8" O.C. | 7" O.C. | 7" O.C. |

+/- 76PSF DESIGN PRESSURE AT 168" SPAN INSIDE MOUNT

MAX SUPERIMPOSED LOADS/FT
SPAN 168" AND +/-76PSF
TENSION 862 LBS
SHEAR 532 LBS

| ANCHOR | | MIN EMBED | MIN EDGE DIST | SPANS TO: 60" | SPANS TO: 72" | SPANS TO: 84" | SPANS TO: 96" | SPANS TO: 108" | SPANS TO: 120" | SPANS TO: 132" | SPANS TO: 144" | SPANS TO: 156" | SPANS TO: 168" |
|--------------|---|-----------|---------------|---------------|---------------|---------------|---------------|----------------|----------------|----------------|----------------|----------------|----------------|
| WOOD SG=0.55 | 1/4"ELCO PANELMATE MALE OR FEMALE | 1-7/8" | 3/4" | 10" O.C. | 9" O.C. | 8" O.C. | 6" O.C. | 6" O.C. | | | | | |
| | 1/4"ELCO PANELMATE MALE OR FEMALE | 1-1/2" | 2" | 12" O.C. | 10" O.C. | 9" O.C. | 8" O.C. | 7" O.C. | 6" O.C. | | | | |
| | 1/4" LAG BOLT | 3" | 2" | 12" O.C. | 12" O.C. | 12" O.C. | 12" O.C. | 12" O.C. | 12" O.C. | 11" O.C. | 10" O.C. | 9" O.C. | 9" O.C. |
| | 3/8" LAG BOLT | 3" | 3" | 12" O.C. | 12" O.C. | 12" O.C. | 12" O.C. | 12" O.C. | 12" O.C. | 12" O.C. | 12" O.C. | 12" O.C. | 12" O.C. |
| | 3/8" LAG OR HANGER BOLT W/2"X3"X3/16" ALUM. ANGLE | 3" | 3" | 24" O.C. | 24" O.C. | 24" O.C. | 24" O.C. | 24" O.C. | 24" O.C. | | | | |

| | | | | | | | | | | | | | |
|------------------|----------------------------|---------|---------|----------|----------|----------|----------|----------|---------|---------|---------|---------|---------|
| CONCRETE 3000psi | 1/4"ELCO PANELMATE MALE | 2" | 2-1/2" | 12" O.C. | 11" O.C. | 9" O.C. | 8" O.C. | 7" O.C. | 6" O.C. | 6" O.C. | | | |
| | 1/4"ELCO PANELMATE FEMALE | 1-3/4" | 2-1/2" | 11" O.C. | 9" O.C. | 8" O.C. | 7" O.C. | 6" O.C. | | | | | |
| | 1/4" ELCO PANELMATE INSERT | 1-5/8" | 4" | 12" O.C. | 12" O.C. | 10" O.C. | 9" O.C. | 8" O.C. | 7" O.C. | 6" O.C. | 6" O.C. | | |
| | 1/4-20 POWERS CALK-IN | 7/8" | 3" | 10" O.C. | 9" O.C. | 7" O.C. | 6" O.C. | 6" O.C. | | | | | |
| | 1/4" TAPCON | 1-3/4" | 2-1/2" | 12" O.C. | 10" O.C. | 8" O.C. | 7" O.C. | 6" O.C. | 6" O.C. | | | | |
| | 5/16" TAPCON | 2-1/4" | 2-3/16" | 12" O.C. | 12" O.C. | 12" O.C. | 12" O.C. | 10" O.C. | 9" O.C. | 9" O.C. | 8" O.C. | 7" O.C. | 7" O.C. |
| | 3/8-16 POWERS CALK-IN | 1-1/4" | 4" | 12" O.C. | 12" O.C. | 11" O.C. | 9" O.C. | 8" O.C. | 7" O.C. | 7" O.C. | 6" O.C. | | |
| | 3/8 POWERS DROP-IN | 1-9/16" | 2-5/8" | 12" O.C. | 12" O.C. | 12" O.C. | 12" O.C. | 10" O.C. | 9" O.C. | 9" O.C. | 8" O.C. | 7" O.C. | 7" O.C. |

PRODUCT REVISED
as complying with the Florida
Building Code
Acceptance No 16-0921.10
Expiration Date 12/04/2019
By He G. P. Miller
Miami Dade Product Contr.

JORGE A. POMERANTZ, P.E.
FLORIDA LICENSE# 55328
ING CONSULTANTS, INC.
8865 W SUNRISE BLVD
PLANTATION FL 33322
CERT. AUTH. #27242
T: 954.394.8521 F: 954.583.5197
ingconsultants@yahoo.com

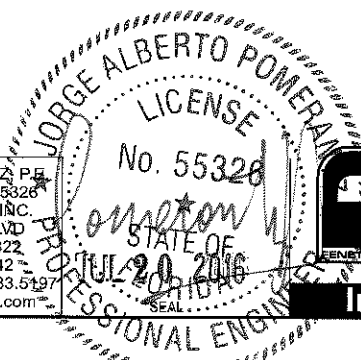

FENETEX
HURRICANE SCREENS

Installation Instructions

278 Talleyrand Ave
Jacksonville, FL 32202
Tel: 904.437.5168
www.fenetex.com

DRAWINGS BY FENETEX, INC.
COPYRIGHT 2013 FENETEX, INC.
INIT ISSUE 09.20.2013
REV 3 06.15.2016

DRAWING NO: 0906131
NOT TO SCALE **7** of 9

ANCHOR SCHEDULE TYPE D CONNECTIONS

BLANK CELLS OR GREATER SPANS
REQUIRE SITE SPECIFIC ENGINEERING

MAX SUPERIMPOSED LOADS/FT
SPAN 120" AND +/-76PSF
TENSION 380 LBS
SHEAR 385 LBS

+/- 76PSF DESIGN PRESSURE AT 120" SPAN OUTSIDE MOUNT

| ANCHOR | | MIN EMBED | MIN EDGE DIST | SPANS TO: 60" | SPANS TO: 72" | SPANS TO: 84" | SPANS TO: 96" | SPANS TO: 108" | SPANS TO: 120" |
|--------------|--------------------------------------|--------------|------------------|------------------|------------------|------------------|------------------|-------------------|-------------------|
| WOOD SG=0.55 | 1/4"ELCO PANELMATE MALE OR FEMALE | 1-7/8" | 3/4" | 12" O.C. | 10" O.C. | 9" O.C. | 8" O.C. | 7" O.C. | 6" O.C. |
| | 1/4"ELCO PANELMATE MALE OR FEMALE | 1-1/2" | 2" | 12" O.C. | 12" O.C. | 11" O.C. | 9" O.C. | 8" O.C. | 8" O.C. |
| | 1/4" LAG BOLT | 3" | 1-3/4" | 12" O.C. | 12" O.C. | 12" O.C. | 12" O.C. | 12" O.C. | 12" O.C. |

| | | | | | | | | | |
|-------------------|------------------------------|--------|--------|----------|----------|----------|----------|----------|---------|
| CONCRETE 3000 psi | 1/4"ELCO PANELMATE MALE | 2" | 2-1/2" | 12" O.C. | 12" O.C. | 12" O.C. | 11" O.C. | 10" O.C. | 9" O.C. |
| | 1/4"ELCO PANELMATE FEMALE | 1-3/4" | 2-1/2" | 12" O.C. | 12" O.C. | 10" O.C. | 9" O.C. | 8" O.C. | 7" O.C. |
| | 1/4" ELCO PANELMATE INSERT | 1-5/8" | 4" | 12" O.C. | 12" O.C. | 12" O.C. | 11" O.C. | 10" O.C. | 9" O.C. |
| | 1/4-20 POWERS CALK-IN | 7/8" | 3" | 12" O.C. | 11" O.C. | 9" O.C. | 8" O.C. | 7" O.C. | 6" O.C. |
| | 1/4" TAPCON | 1-3/4" | 2-1/2" | 12" O.C. | 12" O.C. | 10" O.C. | 9" O.C. | 8" O.C. | 7" O.C. |

MAX SUPERIMPOSED LOADS/FT
SPAN 120" AND +/-76PSF
TENSION 1150 LBS
SHEAR 380 LBS

+/- 76PSF DESIGN PRESSURE AT 120" SPAN INSIDE MOUNT

| ANCHOR | | MIN EMBED | MIN EDGE DIST | SPANS TO: 60" | SPANS TO: 72" | SPANS TO: 84" | SPANS TO: 96" | SPANS TO: 108" | SPANS TO: 120" |
|--------------|--------------------------------------|--------------|------------------|------------------|------------------|------------------|------------------|-------------------|-------------------|
| WOOD SG=0.55 | 1/4"ELCO PANELMATE MALE OR FEMALE | 1-7/8" | 3/4" | 8" O.C. | 6" O.C. | 5" O.C. | 5" O.C. | 4" O.C. | 4" O.C. |
| | 1/4"ELCO PANELMATE MALE OR FEMALE | 1-1/2" | 2" | 8" O.C. | 7" O.C. | 6" O.C. | 5" O.C. | 5" O.C. | 4" O.C. |
| | 1/4" LAG BOLT | 3" | 1-3/4" | 12" O.C. | 12" O.C. | 12" O.C. | 12" O.C. | 10" O.C. | 9" O.C. |

| | | | | | | | | | |
|-------------------|------------------------------|--------|--------|---------|---------|---------|---------|---------|---------|
| CONCRETE 3000 psi | 1/4"ELCO PANELMATE MALE | 2" | 2-1/2" | 9" O.C. | 7" O.C. | 6" O.C. | 5" O.C. | 5" O.C. | 4" O.C. |
| | 1/4"ELCO PANELMATE FEMALE | 1-3/4" | 2-1/2" | 8" O.C. | 6" O.C. | 5" O.C. | 5" O.C. | 4" O.C. | 4" O.C. |
| | 1/4" ELCO PANELMATE INSERT | 1-5/8" | 4" | 9" O.C. | 7" O.C. | 6" O.C. | 5" O.C. | 5" O.C. | 4" O.C. |
| | 1/4-20 POWERS CALK-IN | 7/8" | 3" | 7" O.C. | 6" O.C. | 5" O.C. | 4" O.C. | 4" O.C. | / |
| | 1/4" TAPCON | 1-3/4" | 2-1/2" | 8" O.C. | 6" O.C. | 5" O.C. | 5" O.C. | 4" O.C. | 4" O.C. |

PRODUCT REVISED
as complying with the Florida
Building Code
Acceptance No 16-0921-10
Expiration Date 12/04/2019
By [Signature]
Miami Dade Product Control

JORGE A. POMERANTZ
FLORIDA LICENSE# 55326
ING CONSULTANTS, INC.
8865 W SUNRISE BLVD
PLANTATION FL 33322
CERT. AUTH. #27242
T: 954.394.8521 F: 954.583.5197
ingconsultants@yahoo.com

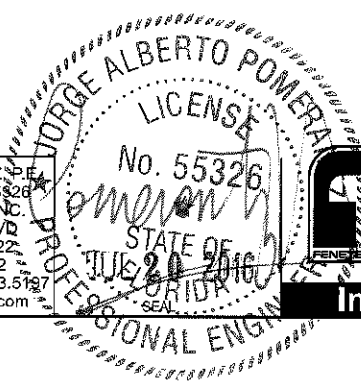

FENETEX
HURRICANE SCREENS

Installation Instructions

278 Talleyrand Ave
Jacksonville, FL 32202
Tel: 904.437.5168
www.fenetex.com

DRAWINGS BY FENETEX, INC.
COPYRIGHT 2013 FENETEX, INC.
INIT ISSUE 08.20.2013
REV 3 06.13.2016

DRAWING NO: 0906131
NOT TO SCALE

8
9

ANCHOR SCHEDULE TYPE E CONNECTIONS

BLANK CELLS OR GREATER SPANS
REQUIRE SITE SPECIFIC ENGINEERING

**+/- 76PSF DESIGN PRESSURE AT 192" SPAN
OUTSIDE MOUNT**

MAX SUPERIMPOSED LOADS/FT
SPAN 192" AND +/-76PSF
TENSION 608 LBS
SHEAR 1024 LBS

| ANCHOR | | MIN EMBED | MIN EDGE DIST | SPANS TO: 132" | SPANS TO: 144" | SPANS TO: 156" | SPANS TO: 168" | SPANS TO: 180" | SPANS TO: 192" |
|---------------------|--------------------------------------|-----------|---------------|----------------|----------------|----------------|----------------|----------------|----------------|
| CONCRETE 4000psi | 3/8" POWERS DROP-IN | 1-9/16" | 5-1/4" | 12" O.C. | 11" O.C. | 10" O.C. | 9" O.C. | 9" O.C. | 8" O.C. |
| | 1/2" POWERS DROP-IN | 2" | 7" | 17" O.C. | 15" O.C. | 14" O.C. | 13" O.C. | 12" O.C. | 11" O.C. |
| | 1/2" THREADED ROD W/POWER-FAST EPOXY | 3" | 3" | 18" O.C. | 18" O.C. | 18" O.C. | 18" O.C. | 18" O.C. | 18" O.C. |

**+/- 76PSF DESIGN PRESSURE AT 192" SPAN
INSIDE MOUNT**

MAX SUPERIMPOSED LOADS/FT
SPAN 192" AND +/-76PSF
TENSION 1024 LBS
SHEAR 608 LBS

| ANCHOR | | MIN EMBED | MIN EDGE DIST | SPANS TO: 132" | SPANS TO: 144" | SPANS TO: 156" | SPANS TO: 168" | SPANS TO: 180" | SPANS TO: 192" |
|---------------------|--------------------------------------|-----------|---------------|----------------|----------------|----------------|----------------|----------------|----------------|
| CONCRETE 4000psi | 3/8" POWERS DROP-IN | 1-9/16" | 5-1/4" | 12" O.C. | 11" O.C. | 10" O.C. | 9" O.C. | 8" O.C. | 8" O.C. |
| | 1/2" POWERS DROP-IN | 2" | 7" | 16" O.C. | 15" O.C. | 14" O.C. | 13" O.C. | 12" O.C. | 11" O.C. |
| | 1/2" THREADED ROD W/POWER-FAST EPOXY | 3" | 3" | 18" O.C. | 18" O.C. | 18" O.C. | 18" O.C. | 18" O.C. | 18" O.C. |

ANCHOR SCHEDULE END RETENTION SCREENS

BLANK CELLS OR GREATER SPANS
REQUIRE SITE SPECIFIC ENGINEERING

+/- 76PSF DESIGN PRESSURE AT 192" SPAN OUTSIDE MOUNT

MAX SUPERIMPOSED LOADS/FT
SPAN 192" AND +/-76PSF
TENSION 2680 LBS
SHEAR 985 LBS

| | | MIN EMBED | MIN EDGE DIST | SPANS TO: 80" | SPANS TO: 72" | SPANS TO: 84" | SPANS TO: 96" | SPANS TO: 108" | SPANS TO: 120" | SPANS TO: 132" | SPANS TO: 144" | SPANS TO: 156" | SPANS TO: 192" |
|-----------------|-------------------|-----------|---------------|---------------|---------------|---------------|---------------|----------------|----------------|----------------|----------------|----------------|----------------|
| WOOD SG=0.55 | 1/4 x 4" LAG BOLT | 3" | 1-3/4" | 6" O.C. | 6" O.C. | 6" O.C. | 6" O.C. | 6" O.C. | 6" O.C. | / | / | / | / |
| | 3/8 x 4" LAG BOLT | 3" | 1-3/4" | 6" O.C. | 6" O.C. | 6" O.C. | 6" O.C. | 6" O.C. | 6" O.C. | / | / | / | / |

| | | MIN EMBED | MIN EDGE DIST | SPANS TO: 60" | SPANS TO: 72" | SPANS TO: 84" | SPANS TO: 96" | SPANS TO: 108" | SPANS TO: 120" | SPANS TO: 132" | SPANS TO: 144" | SPANS TO: 156" | SPANS TO: 192" |
|---------------------|------------------------|-----------|---------------|---------------|---------------|---------------|---------------|----------------|----------------|----------------|----------------|----------------|----------------|
| CONCRETE 3000psi | 5/16" TAPCON XL | 2-1/4" | 2-1/4" | 6" O.C. | 6" O.C. | 6" O.C. | 5" O.C. | 4" O.C. | 4" O.C. | 4" O.C. | 3" O.C. | 3" O.C. | / |
| | 3/8" POWERS POWER BOLT | 2-1/2" | 4" | 6" O.C. | 6" O.C. | 6" O.C. | 6" O.C. | 6" O.C. | 5" O.C. | 5" O.C. | 4" O.C. | 4" O.C. | 3" O.C. |
| | 3/8" POWERS POWER STUD | 3" | 4" | 6" O.C. | 6" O.C. | 6" O.C. | 6" O.C. | 6" O.C. | 5" O.C. | 5" O.C. | 4" O.C. | 4" O.C. | 3" O.C. |

+/- 76PSF DESIGN PRESSURE AT 168" SPAN INSIDE MOUNT

MAX SUPERIMPOSED LOADS/FT
SPAN 168" AND +/-76PSF
TENSION 3556 LBS
SHEAR 532 LBS

| ANCHOR | | MIN EMBED | MIN EDGE DIST | SPANS TO: 60" | SPANS TO: 72" | SPANS TO: 84" | SPANS TO: 96" | SPANS TO: 108" | SPANS TO: 120" | SPANS TO: 132" | SPANS TO: 144" | SPANS TO: 156" | SPANS TO: 168" |
|---------------------|------------------------|-----------|---------------|---------------|---------------|---------------|---------------|----------------|----------------|----------------|----------------|----------------|----------------|
| CONCRETE 3000psi | 5/16" TAPCON XL | 2-1/4" | 2-1/4" | 4" O.C. | 4" O.C. | 4" O.C. | 4" O.C. | 3" O.C. | 3" O.C. | 3" O.C. | / | / | / |
| | 3/8" POWERS POWER BOLT | 2-1/2" | 4" | 4" O.C. | 4" O.C. | 4" O.C. | 4" O.C. | 4" O.C. | 4" O.C. | 4" O.C. | 3" O.C. | 3" O.C. | 3" O.C. |
| | 3/8" POWERS POWER STUD | 3" | 4" | 4" O.C. | 4" O.C. | 4" O.C. | 4" O.C. | 4" O.C. | 4" O.C. | 3" O.C. | 3" O.C. | 3" O.C. | / |

PRODUCT REVISED
as complying with the Florida
Building Code
Acceptance No 16-0921.10
Expiration Date 12/04/2019
By [Signature]
Miami Dade Product Control

JORGE A. POMERANTZ, P.E.
FLORIDA LICENSE# 55326
ING CONSULTANTS, INC.
8865 W SUNRISE BLVD
PLANTATION FL 33322
CERT. AUTH. #27242
T: 954.394.8521 F: 954.583.5197
ingconsultants@yahoo.com

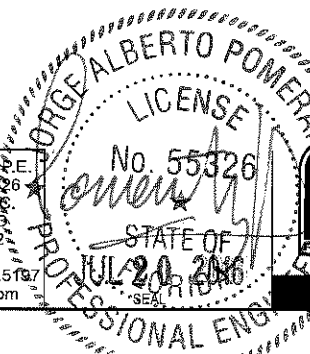

FENETEX
HURRICANE SCREENS

Installation Instructions

FENETEX Incorporated
278 Talleyrand Ave
Jacksonville, FL 32202
Tel: 904.437.5168
www.fenetex.com

DRAWINGS BY FENETEX, INC.
COPYRIGHT 2013 FENETEX, INC.
INIT ISSUE 09.20.2013
REV 3 06.13.2016

DRAWING NO: 0906131
NOT TO SCALE **9** of 9